

*TB 9-6625-2325-24

DEPARTMENT OF THE ARMY TECHNICAL BULLETIN

CALIBRATION PROCEDURE FOR TRUE RMS VOLTMETER FLUKE, MODELS 8920A AND 8921A

Headquarters, Department of the Army, Washington, DC
25 October 2007

Distribution Statement A: Approved for public release, distribution is unlimited.

REPORTING OF ERRORS AND RECOMMENDING IMPROVEMENTS

You can improve this manual. If you find any mistakes or if you know of a way to improve these procedures, please let us know. Mail your letter or DA Form 2028 (Recommended Changes to Publications and Blank Forms) directly to: Commander, U.S. Army Aviation and Missile Command, ATTN: AMSAM-MMC-MA-NP, Redstone Arsenal, AL 35898-5000. A reply will be furnished to you. You may also send in your comments electronically to our E-mail address: 2028@redstone.army.mil or by fax 256-842-6546/DSN 788-6546. For the World Wide Web use: <https://amcom2028.redstone.army.mil>. Instructions for sending an electronic 2028 can be found at the back of this manual.

SECTION		Paragraph	Page
	I. IDENTIFICATION AND DESCRIPTION		
	Test instrument identification	1	2
	Forms, records, and reports.....	2	2
	Calibration description	3	2
	II. EQUIPMENT REQUIREMENTS		
	Equipment required.....	4	3
	Accessories required.....	5	3
	III. CALIBRATION PROCESS		
	Preliminary instructions.....	6	5
	Equipment setup	7	5
	Low and midband accuracy	8	6
	High frequency response	9	8
	dB display mode	10	11
	Linear analog output (model 8920A only)	11	11
	Power supply	12	12
	Final procedure	13	12

*This bulletin supersedes TB 9-6625-2325-35, dated 17 August 2001, including all changes.

**SECTION I
IDENTIFICATION AND DESCRIPTION**

1. Test Instrument Identification. This bulletin provides instructions for the calibration of True RMS Voltmeter, Fluke, Models 8920A and 8921A. The manufacturer's manual was used as the prime data source in compiling these instructions. The equipment being calibrated will be referred to as the TI (test instrument) throughout this bulletin.

a. Model Variations. Model 8920A has BNC input and model 8921A has double banana input.

b. Time and Technique. The time required for this calibration is approximately 2 hours, using the dc and low frequency technique.

2. Forms, Records, and Reports

a. Forms, records and reports required for calibration personnel at all levels are prescribed by TB 750-25.

b. Adjustments to be reported are designated (R) at the end of the sentence in which they appear. When adjustments are in tables, the (R) follows the designated adjustment. Report only those adjustments made and designated with (R).

3. Calibration Description. TI parameters and performance applications which pertain to this calibration are in table 1.

Table 1. Calibration Description

Test instrument parameters	Performance Specifications							
Ac voltage	Range: 0 to 700 V							
	Accuracy: ±% of voltage reading or (± dB)							
		Range						
	Frequency ¹	2 mV	20 mV	200 mV	2 V	20 V	200 V	700 V
	10 to 20 Hz	5 (0.5)						
	20 to 50 Hz	3 (0.35)	2 (0.25)	1(0.15)				
	50 Hz to 200 kHz	2 (0.25)	1 (0.15)	0.5 (0.5)				
	200 kHz to 1 MHz	3 (0.35)	2 (0.25)	0.7 (0.15)				
	1 to 2 MHz	4 (0.4)		3 (0.35)			N/A	
2 to 10 MHz	N/A	4 (0.4)	3 0(.35)			N/A		
10 to 20 MHz	N/A	5 (0.5)				N/A		

See footnotes at end of table.

Table 1. Calibration Description - Continued

Test instrument parameters	Performance Specifications
Linear analog output (model 8920A only)	Range: 0 to 2 V dc Accuracy: $\pm 1\%$
Ac + dc voltage	Range: 0 to 700 V Accuracy: Add to ac specifications: Above 2 mV $\pm(10$ digits or 0.5 dB) Below 2 mV $\pm(100$ digits or 5 dB) Use 50 Hz to 200 kHz specifications for dc only.
dB display mode	Range: 12 ranges: 50, 75, 93, 110, 124, 135, 150, 300, 600, 900, 1000, and 1200 Ω . dB resolution: 0.01 dB

¹Maximum V Hz product is 1×10^8 .

SECTION II EQUIPMENT REQUIREMENTS

4. Equipment Required. Table 2 identifies the specific equipment to be used in this calibration procedure. This equipment is issued with Secondary Transfer Calibration Standards Sets AN/GSM-286, AN/GSM-287 or AN/GSM-705. Alternate items may be used by the calibrating activity. The items selected must be verified to perform satisfactorily prior to use and must bear evidence of current calibration. The equipment must meet or exceed the minimum use specifications listed in table 2. The accuracies listed in table 2 provide a four-to-one ratio between the standard and TI. Where the four-to-one ratio cannot be met, the actual accuracy of the equipment selected is shown in parenthesis.

5. Accessories Required. The accessories required for this calibration are common usage accessories, issued as indicated in paragraph 4 above, and are not listed in this calibration procedure.

Table 2. Minimum Specifications of Equipment Required

Common name	Minimum use specifications	Manufacturer and model (part number)																																																																																							
CALIBRATOR	<p>Dc voltage: Range: 1 mV to 2.5 V Accuracy: 1 mV, $\pm 0.375\%$ 1 V, $\pm 4\%$ 0.25 and 2.5 V, $\pm 1.12\%$</p> <p>Ac voltage: Range: 1 mV to 600 V Frequency: 10 Hz to 20 MHz</p> <table border="1" data-bbox="407 653 992 1570"> <thead> <tr> <th><u>Frequency</u></th> <th><u>Voltage</u></th> <th><u>Accuracy $\pm(\%)$</u></th> </tr> </thead> <tbody> <tr><td>10 Hz</td><td>1.9 mV to 190 V</td><td>1.25</td></tr> <tr><td>40 Hz</td><td>1.9 mV</td><td>0.75</td></tr> <tr><td></td><td>19 mV</td><td>0.5</td></tr> <tr><td></td><td>190 mV to 600 V</td><td>0.25</td></tr> <tr><td>500 Hz</td><td>1.9 mV</td><td>0.5</td></tr> <tr><td></td><td>100 mV to 100 V</td><td>0.125</td></tr> <tr><td>1 kHz</td><td>1 mV</td><td>0.5</td></tr> <tr><td></td><td>10 mV</td><td>0.25</td></tr> <tr><td></td><td>100 mV to 3 V</td><td>0.125</td></tr> <tr><td>5 kHz</td><td>1.9 mV</td><td>0.5</td></tr> <tr><td></td><td>19 mV</td><td>0.25</td></tr> <tr><td></td><td>190 mV to 190 V</td><td>0.125</td></tr> <tr><td></td><td>600 V</td><td>0.125</td></tr> <tr><td>40 kHz</td><td>600 V</td><td>0.125</td></tr> <tr><td>50 kHz</td><td>100 mV to 100 V</td><td>0.125</td></tr> <tr><td>100 kHz</td><td>19 mV</td><td>0.25</td></tr> <tr><td></td><td>190 mV to 190 V</td><td>0.125</td></tr> <tr><td>190 kHz</td><td>1 mV</td><td>0.5</td></tr> <tr><td>990 kHz</td><td>1 mV</td><td>0.75</td></tr> <tr><td>2 MHz</td><td>1 mV</td><td>1</td></tr> <tr><td>190 kHz</td><td>10 mV</td><td>0.25</td></tr> <tr><td>990 kHz</td><td>10 mV</td><td>0.5</td></tr> <tr><td>5 MHz</td><td>10 mV</td><td>1</td></tr> <tr><td>20 MHz</td><td>10 mV</td><td>1.25</td></tr> <tr><td>190 kHz</td><td>100 mV to 3 V</td><td>0.125</td></tr> <tr><td>990 kHz</td><td>100 mV to 3 V</td><td>0.175</td></tr> <tr><td>5 MHz</td><td>100 mV to 3 V</td><td>0.75</td></tr> <tr><td>20 MHz</td><td>100 mV to 3 V</td><td>1.25</td></tr> </tbody> </table>	<u>Frequency</u>	<u>Voltage</u>	<u>Accuracy $\pm(\%)$</u>	10 Hz	1.9 mV to 190 V	1.25	40 Hz	1.9 mV	0.75		19 mV	0.5		190 mV to 600 V	0.25	500 Hz	1.9 mV	0.5		100 mV to 100 V	0.125	1 kHz	1 mV	0.5		10 mV	0.25		100 mV to 3 V	0.125	5 kHz	1.9 mV	0.5		19 mV	0.25		190 mV to 190 V	0.125		600 V	0.125	40 kHz	600 V	0.125	50 kHz	100 mV to 100 V	0.125	100 kHz	19 mV	0.25		190 mV to 190 V	0.125	190 kHz	1 mV	0.5	990 kHz	1 mV	0.75	2 MHz	1 mV	1	190 kHz	10 mV	0.25	990 kHz	10 mV	0.5	5 MHz	10 mV	1	20 MHz	10 mV	1.25	190 kHz	100 mV to 3 V	0.125	990 kHz	100 mV to 3 V	0.175	5 MHz	100 mV to 3 V	0.75	20 MHz	100 mV to 3 V	1.25	Fluke, Model 5720A (5720A) (p/o MIS-35947); w amplifier, Fluke 5725A/AR (5725A/AR)
<u>Frequency</u>	<u>Voltage</u>	<u>Accuracy $\pm(\%)$</u>																																																																																							
10 Hz	1.9 mV to 190 V	1.25																																																																																							
40 Hz	1.9 mV	0.75																																																																																							
	19 mV	0.5																																																																																							
	190 mV to 600 V	0.25																																																																																							
500 Hz	1.9 mV	0.5																																																																																							
	100 mV to 100 V	0.125																																																																																							
1 kHz	1 mV	0.5																																																																																							
	10 mV	0.25																																																																																							
	100 mV to 3 V	0.125																																																																																							
5 kHz	1.9 mV	0.5																																																																																							
	19 mV	0.25																																																																																							
	190 mV to 190 V	0.125																																																																																							
	600 V	0.125																																																																																							
40 kHz	600 V	0.125																																																																																							
50 kHz	100 mV to 100 V	0.125																																																																																							
100 kHz	19 mV	0.25																																																																																							
	190 mV to 190 V	0.125																																																																																							
190 kHz	1 mV	0.5																																																																																							
990 kHz	1 mV	0.75																																																																																							
2 MHz	1 mV	1																																																																																							
190 kHz	10 mV	0.25																																																																																							
990 kHz	10 mV	0.5																																																																																							
5 MHz	10 mV	1																																																																																							
20 MHz	10 mV	1.25																																																																																							
190 kHz	100 mV to 3 V	0.125																																																																																							
990 kHz	100 mV to 3 V	0.175																																																																																							
5 MHz	100 mV to 3 V	0.75																																																																																							
20 MHz	100 mV to 3 V	1.25																																																																																							
MULTIMETER	Range: -15.2 to +15.1 V dc Accuracy: $\pm 0.17\%$	Fluke, Model 8840A/AF05 (AN/GSM-64D)																																																																																							

SECTION III CALIBRATION PROCESS

6. Preliminary Instructions

a. The instructions outlined in paragraphs 6 and 7 are preparatory to the calibration process. Personnel should become familiar with the entire bulletin before beginning the calibration.

b. Items of equipment used in this procedure are referenced within the text by common name as listed in table 2.

c. Unless otherwise specified, verify the result of each test and, whenever the test requirement is not met, take corrective action before continuing with the calibration. Adjustments required to calibrate the TI are included in this procedure. Additional maintenance information is contained in the manufacturer's manual for this TI.

d. When indications specified in paragraphs 8 through 11 are not within tolerance, perform the power supply check prior to making adjustments. After adjustments are made, repeat paragraphs 8 through 11. Do not perform power supply check if all other parameters are within tolerance.

e. Unless otherwise specified, all controls and control settings refer to the TI.

7. Equipment Setup

WARNING

HIGH VOLTAGE is used or exposed during the performance of this calibration. DEATH ON CONTACT may result if personnel fail to observe safety precautions. REDUCE OUTPUT(S) to minimum after each step within the performance check where applicable.

a. Remove top cover from TI by removing four bottom screws.

b. Observe that slide switches S209 and S210 (fig. 1) are set for proper 120 V operation (both slide switches to left with white dot toward rear).

c. Replace top cover but do not secure with screws.

NOTE

All test points and adjustments are shown in figure 1. Remove top cover only to make connections or adjustments and replace immediately upon completion.

d. Connect TI to a 115 V ac power source.

e. Press **POWER** pushbutton to **ON** and allow at least 1 hour for warm-up.

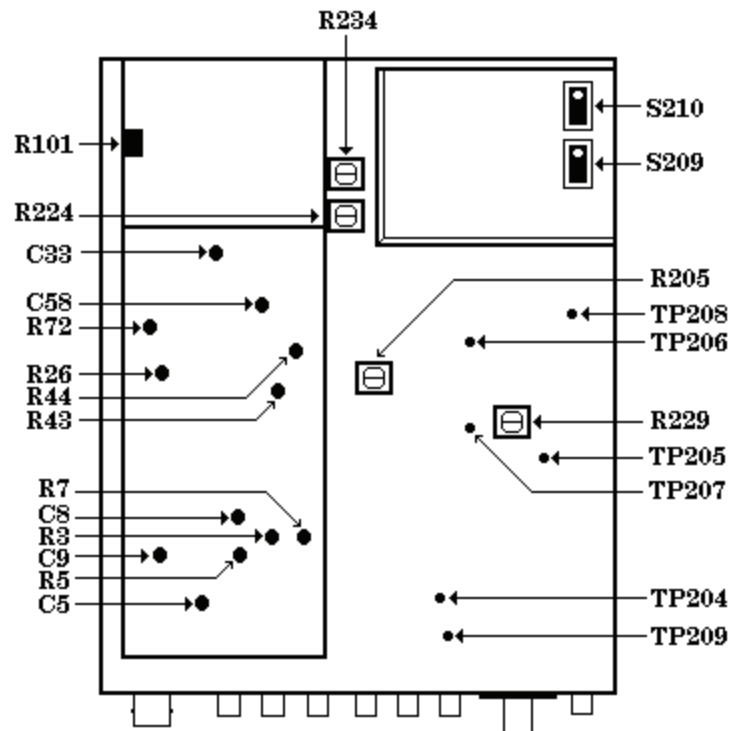

Figure 1. Test points and adjustment locations - top view.

8. Low and Midband Accuracy

a. Performance Check

- (1) Connect calibrator **OUTPUT HI** and **LO** to **TI INPUT**.
- (2) Press and release all front panel pushbuttons to out position, except **LO RANGE ENABLE** and **POWER**.
- (3) Connect a short between TP204 and TP209 (fig. 1).
- (4) Set calibrator for a 1 V, 500 Hz output. Record TI indication.
- (5) Press **RANGE HOLD/AUTO** pushbutton to **HOLD**.
- (6) Set calibrator for a 0.1 V, 500 Hz output. If TI does not indicate one-tenth of value recorded in (4) above, perform **b** (1) and (2) below.
- (7) Press and release **RANGE HOLD/AUTO** pushbutton to **AUTO**.
- (8) Set calibrator for a 2.5 V dc output.
- (9) Press **FUNCTION AC+DC/AC** pushbutton to **AC+DC**. If TI does not indicate between 2.388 and 2.612 V, perform **b** (3) below.
- (10) Set calibrator for a 0.25 V dc output. If TI does not indicate between 0.2388 and 0.2612 V, perform **b** (4) below.

- (11) Press and release **FUNCTION AC+DC/AC** pushbutton to **AC**.
- (12) Set calibrator for voltages and frequencies listed in table 3. If TI does not indicate within limits specified, perform appropriate adjustments.
- (13) Remove short connected between TP204 and TP209 (fig. 1).

Table 3. Low and Midband Accuracy (10 Hz to 100 kHz)

Calibrator output		Test instrument indications			
Frequency	Voltage	Range	Min	Max	Adjustments (R)
500 Hz	100 mV	200 mV	99.50 mV	100.50 mV	R205 ¹
500 Hz	1.9 mV	2 mV	1.8620 mV	1.9380 mV	R44 ¹
50 kHz	100 mV	200 mV	99.50 mV	100.50 mV	C9
500 Hz	1 V	2 V	.9950 V	1.0050 V	R3
500 Hz	100 V	200 V	99.50 V	100.50 V	R7
50 kHz	1 V	2 V	.9950 V	1.0050 V	C5 ²
50 kHz	100 V	200 V	99.50 V	100.50 V	C8 ²
10 Hz	1.9 mV	2 mV	1.8050 mV	1.9950 mV	---
40 Hz	1.9 mV	2 mV	1.8430 mV	1.9570 mV	---
5 kHz	1.9 mV	2 mV	1.8620 mV	1.9380 mV	---
10 Hz	19 mV	20 mV	18.050 mV	19.950 mV	---
40 Hz	19 mV	20 mV	18.620 mV	19.380 mV	---
5 kHz	19 mV	20 mV	18.810 mV	19.190 mV	---
100 kHz	19 mV	20 mV	18.810 mV	19.190 mV	---
10 Hz	190 mV	200 mV	180.50 mV	199.50 mV	---
40 Hz	190 mV	200 mV	188.10 mV	191.95 mV	---
5 kHz	190 mV	200 mV	189.05 mV	190.95 mV	---
100 kHz	190 mV	200 mV	189.05 mV	190.95 mV	---
10 Hz	1.9 V	2 V	1.8050 V	1.9950 V	---
40 Hz	1.9 V	2 V	1.8810 V	1.9190 V	---
5 kHz	1.9 V	2 V	1.8905 V	1.9095 V	---
100 kHz	1.9 V	2 V	1.8905 V	1.9095 V	---
10 Hz	19 V	20 V	18.050 V	19.950 V	---
40 Hz	19 V	20 V	18.810 V	19.190 V	---
5 kHz	19 V	20 V	18.905 V	19.095 V	---
100 kHz	19 V	20 V	18.905 V	19.095 V	---
10 Hz	190 V	200 V	180.50 V	199.50 V	---
40 Hz	190 V	200 V	188.10 V	191.90 V	---
5 kHz	190 V	200 V	189.05 V	190.95 V	---
100 kHz	190 V	200 V	189.05 V	190.95 V	---
40 Hz	600 V	700 V	594.00 V	606.00 V	---
5 kHz	600 V	700 V	597.00 V	603.00 V	---
40 kHz	600 V	700 V	597.00 V	603.00 V	---
+DC ³	1 V	2 V	.9850 V	1.0150 V	---
+DC	1 mV	AUTO	.8800 mV	1.1200 mV	---

¹Interaction exists between R44 and R205 (fig. 1). Repeat both adjustments as required.

²Interaction exists between C8 and C5 (fig. 1). Repeat both adjustments as required.

³Press **FUNCTION AC+DC/AC** pushbutton to **AC+DC**.

b. Adjustments

- (1) Adjust R101 (fig. 1) until TI indicates one-tenth of value recorded in **a** (4) above (R).
- (2) Press and release **RANGE HOLD/AUTO** pushbutton to **AUTO** and repeat **a** (4) through (6) above.

NOTE

Due to the coarseness of adjustments in (3) and (4) below, it is only necessary to adjust within the tolerance listed.

- (3) Adjust R72 (fig. 1) until TI indicates between 2.49 and 2.51 V (R).
- (4) Adjust R26 (fig 1.) until TI indicates between 0.249 and 0.251 V and repeat **a** (8) through (10) above (R).

9. High Frequency Response

a. Performance Check

- (1) Connect calibrator **OUTPUT HI** and **LO** to **TI INPUT**.
- (2) Press and release all front panel pushbuttons to out position, except **LO RANGE ENABLE** and **POWER**.
- (3) Set calibrator for a 1 mV, 1 kHz output. TI will indicate between 0.98 and 1.02 mV. Record TI indication.
- (4) Set calibrator for a 10 mV, 1 kHz output. TI will indicate between 9.9 and 10.1 mV. Record TI indication
- (5) Set calibrator for a 100 mV, 1 kHz output. TI will indicate between 99.5 and 100.5 mV. Record TI indication.
- (6) Set calibrator for a 1 V, 1 kHz output. TI will indicate between 0.995 and 1.005 V. Record TI indication.
- (7) Set calibrator for a 3 V, 1 kHz output. TI will indicate between 2.985 and 3.015 V. Record TI indication.
- (8) Connect calibrator **WIDEBAND** to **TI INPUT** using calibrator wideband cable and 50 Ω feedthrough termination.
- (9) Set calibrator for a 1 mV, 1 kHz wideband output.
- (10) Adjust calibrator amplitude output adjustment controls until TI indication equals TI indication recorded in (3) above, then press calibrator **NEW REF** key.
- (11) Set calibrator to 2 MHz and adjust amplitude output adjustment controls until TI indication equals TI indication recorded in (3) above. If calibrator **Error** display indication is not within ± 4 percent, perform **b** (1) below.
- (12) Set calibrator to 990 kHz and adjust amplitude output adjustment controls until TI indication equals TI indication recorded in (3) above. Calibrator **Error** display indication will be within ± 3 percent.

(13) Set calibrator to 190 kHz and adjust amplitude output adjustment controls until TI indication equals TI indication recorded in (3) above. Calibrator **Error** display indication will be within ± 2 percent.

(14) Set calibrator for a 10 mV, 1 kHz wideband output.

(15) Adjust calibrator amplitude output adjustment controls until TI indication equals TI indication recorded in (4) above, then press calibrator **NEW REF** key.

(16) Set calibrator to 20 MHz and adjust amplitude output adjustment controls until TI indication equals TI indication recorded in (4) above. If calibrator **Error** display indication is not within ± 5 percent, perform **b** (2) below.

(17) Set calibrator to 5 MHz and adjust amplitude output adjustment controls until TI indication equals TI indication recorded in (4) above. Calibrator **Error** display indication will be within ± 4 percent.

(18) Set calibrator to 990 kHz and adjust amplitude output adjustment controls until TI indication equals TI indication recorded in (4) above. Calibrator **Error** display indication will be within ± 2 percent.

(19) Set calibrator to 190 kHz and adjust amplitude output adjustment controls until TI indication equals TI indication recorded in (4) above. Calibrator **Error** display indication will be within ± 1 percent.

(20) Set calibrator for a 100 mV, 1 kHz wideband output.

(21) Adjust calibrator amplitude output adjustment controls until TI indication equals TI indication recorded in (5) above, then press calibrator **NEW REF** key.

(22) Set calibrator to 20 MHz and adjust amplitude output adjustment controls until TI indication equals TI indication recorded in (5) above. If calibrator **Error** display indication is not within ± 5 percent, perform **b** (3) below.

(23) Set calibrator to 5 MHz and adjust amplitude output adjustment controls until TI indication equals TI indication recorded in (5) above. Calibrator **Error** display indication will be within ± 3 percent.

(24) Set calibrator to 990 kHz and adjust amplitude output adjustment controls until TI indication equals TI indication recorded in (5) above. Calibrator **Error** display indication will be within ± 0.7 percent.

(25) Set calibrator to 190 kHz and adjust amplitude output adjustment controls until TI indication equals TI indication recorded in (5) above. Calibrator **Error** display indication will be within ± 0.5 percent.

(26) Set calibrator for a 1 V, 1 kHz wideband output.

(27) Adjust calibrator amplitude output adjustment controls until TI indication equals TI indication recorded in (6) above, then press calibrator **NEW REF** key.

(28) Set calibrator to 20 MHz and adjust amplitude output adjustment controls until TI indication equals TI indication recorded in (6) above. If calibrator **Error** display indication is not within ± 5 percent, perform **b** (4) below.

(29) Set calibrator to 5 MHz and adjust amplitude output adjustment controls until TI indication equals TI indication recorded in (6) above. Calibrator **Error** display indication will be within ± 3 percent.

(30) Set calibrator to 990 kHz and adjust amplitude output adjustment controls until TI indication equals TI indication recorded in (6) above. Calibrator **Error** display indication will be within ± 0.7 percent.

(31) Set calibrator to 190 kHz and adjust amplitude output adjustment controls until TI indication equals TI indication recorded in (6) above. Calibrator **Error** display indication will be within ± 0.5 percent.

(32) Set calibrator for a 3 V, 1 kHz wideband output.

(33) Adjust calibrator amplitude output adjustment controls until TI indication equals TI indication recorded in (7) above, then press calibrator **NEW REF** key.

(34) Set calibrator to 190 kHz and adjust amplitude output adjustment controls until TI indication equals TI indication recorded in (7) above. Calibrator **Error** display indication will be within ± 0.5 percent.

(35) Set calibrator to 990 kHz and adjust amplitude output adjustment controls until TI indication equals TI indication recorded in (7) above. Calibrator **Error** display indication will be within ± 0.7 percent.

(36) Set calibrator to 5 MHz and adjust amplitude output adjustment controls until TI indication equals TI indication recorded in (7) above. Calibrator **Error** display indication will be within ± 3 percent.

(37) Set calibrator to 20 MHz and adjust amplitude output adjustment controls until TI indication equals TI indication recorded in (7) above. Calibrator **Error** display indication will be within ± 5 percent.

b. Adjustments

(1) Adjust calibrator amplitude output adjustment controls for a 0 percent **Error** display indication and adjust R43 (fig. 1) until TI indication equals TI indication recorded in **a** (3) above (R).

(2) Adjust calibrator amplitude output adjustment controls for a 0 percent **Error** display indication and adjust C33 (fig. 1) until TI indication equals TI indication recorded in **a** (4) above (R).

(3) Adjust calibrator amplitude output adjustment controls for a 0 percent **Error** display indication and adjust C58 (fig. 1) until TI indication equals TI indication recorded in **a** (5) above (R).

(4) Adjust calibrator amplitude output adjustment controls for a 0 percent **Error** display indication and adjust R5 (fig. 1) until TI indication equals TI indication recorded in **a** (6) above (R).

10. dB Display Mode

a. Performance Check

- (1) Connect calibrator **OUTPUT HI** and **LO** to **TI INPUT**.
- (2) Press and release all front panel pushbuttons to out position, except **POWER**.
- (3) Press **RANGE HOLD/AUTO** pushbutton to **HOLD** and **STEP UP** pushbutton to **2 V** range.
- (4) Set calibrator for a 1 V, 50 kHz output. Adjust calibrator amplitude output adjustment controls for a 1.000 V TI indication.
- (5) Press **DISPLAY dB/VOLTS** pushbutton to **dB**.
- (6) Set **dBm REFERENCE (Ω)** switch to **50**. TI will indicate between +12.99 and +13.01 dB.
- (7) Set **dBm REFERENCE (Ω)** switch to settings listed in table 4. TI will indicate within limits specified.

Table 4. dB Display Mode

Test instrument		
dBm REFERENCE (Ω) switch settings	Indications (dB)	
	Min	Max
75	+11.23	+11.25
93	+10.30	+10.32
110	+9.57	+9.59
124	+9.05	+9.07
135	+8.68	+8.70
150	+8.22	+8.24
300	+5.21	+5.23
600	+2.20	+2.22
900	+ .44	+ .46
1000	- .00	- .02
1200	- .79	- .81

- (8) Set calibrator for a 1 V, 50 kHz output.
- (9) Press **DISPLAY REL/dBm** pushbutton to **REL**. TI will indicate between -0.01 and +0.01 dB.
- (10) Press and release **RANGE HOLD/AUTO** pushbutton to **AUTO**.
- (11) Adjust calibrator for a 10 V, 50 kHz output. TI will indicate between +19.99 and +20.01 dB.

b. Adjustments. No adjustments can be made.

11. Linear Analog Output (Model 8920A Only)

a. Performance Check

- (1) Connect calibrator **OUTPUT HI** and **LO** to **TI INPUT**.
- (2) Connect multimeter **INPUT HI** and **LO** to TI rear panel **LINEAR ANALOG OUTPUT**.

(3) Press and release all front panel pushbuttons to out position, except **POWER**.

(4) Set calibrator for a 1 V, 500 Hz output. If multimeter does not indicate a dc voltage equivalent to TI display within ± 1 percent, perform **b** (1) below.

(5) Press **RANGE HOLD/AUTO** pushbutton to **HOLD** and set calibrator for a 100 mV, 500 Hz output. If multimeter does not indicate a dc voltage equivalent to TI display within ± 1 percent, perform **b** (2) and (3) below.

(6) Set calibrator for a 500 mV, 500 Hz output. Multimeter will indicate a dc voltage equivalent to TI display within ± 1 percent.

b. Adjustments

(1) Adjust R224 (fig. 1) until multimeter indicates a dc voltage equivalent to TI display (R).

(2) Adjust R234 (fig. 1) until multimeter indicates a dc voltage equivalent to TI display (R).

(3) Repeat **a** (3) through (5) above for best compromise.

12. Power Supply

NOTE

Do not perform power supply check if all other parameters are within tolerance.

a. Performance Check

(1) Press and release all front panel pushbuttons except **POWER**.

CAUTION

To avoid damage to equipment, do not adjust ± 15 V supplies with TI in over range.

(2) Connect multimeter **INPUT HI** to TP206 and **INPUT LO** to TP205 (fig. 1). If multimeter does not indicate between +14.90 and +15.10 V, perform **b** (1) below.

(3) Connect multimeter **INPUT HI** to TP208 (fig. 1). If multimeter does not indicate between -14.80 and -15.20, perform **b** (2) below.

(4) Connect multimeter **INPUT HI** to TP207 (fig. 1). Multimeter will indicate between +4.75 and +5.25 V.

b. Adjustments

(1) Adjust R229 (fig. 1) until multimeter indicates +15.00 V (R).

(2) Readjust R229 (fig. 1) for best in-tolerance compromise for both -15 and +15 V at TP208 and TP206 (fig. 1).

13. Final Procedure

a. Deenergize and disconnect all equipment.

b. Annotate and affix DA label/form in accordance with TB 750-25.

By Order of the Secretary of the Army:

Official:



JOYCE E. MORROW
*Administrative Assistant to the
Secretary of the Army*

0723903

GEORGE W. CASEY, JR.
*General, United States Army
Chief of Staff*

Distribution:

To be distributed in accordance with the initial distribution number (IDN) 344725 requirements for calibration procedure TB 9-6625-2325-24.

Instructions for Submitting an Electronic 2028

The following format must be used if submitting an electronic 2028. The subject line must be exactly the same and all fields must be included; however, only the following fields are mandatory: 1, 3, 4, 5, 6, 7, 8, 9, 10, 13, 15, 16, 17, and 27.

From: "Whomever" whomever@redstone.army.mil

To: <2028@redstone.army.mil

Subject: DA Form 2028

1. **From:** Joe Smith
2. **Unit:** home
3. **Address:** 4300 Park
4. **City:** Hometown
5. **St:** MO
6. **Zip:** 77777
7. **Date Sent:** 19-OCT -93
8. **Pub no:** 55-2840-229-23
9. **Pub Title:** TM
10. **Publication Date:** 04-JUL-85
11. **Change Number:** 7
12. **Submitter Rank:** MSG
13. **Submitter FName:** Joe
14. **Submitter MName:** T
15. **Submitter LName:** Smith
16. **Submitter Phone:** 123-123-1234
17. **Problem:** 1
18. **Page:** 2
19. **Paragraph:** 3
20. **Line:** 4
21. **NSN:** 5
22. **Reference:** 6
23. **Figure:** 7
24. **Table:** 8
25. **Item:** 9
26. **Total:** 123
27. **Text**

This is the text for the problem below line 27.

